

# **JBC**

[www.jbctools.com](http://www.jbctools.com)

## **INSTRUCTION MANUAL**



### **FAE070**

Flexible Arm + Clamp Ø 50 mm

# Packing List

The following items are included:



**Flexible Arm** ..... 1 unit  
Ref. FAE070



**Clamp** ..... 2 units  
Ref. 0018940



**Screws\*** ..... 2 units  
Ref. 0018681



**Washers\*** ..... 2 units  
Ref. 0018877



**Manual** ..... 1 unit  
Ref. 0019184

## Assembly

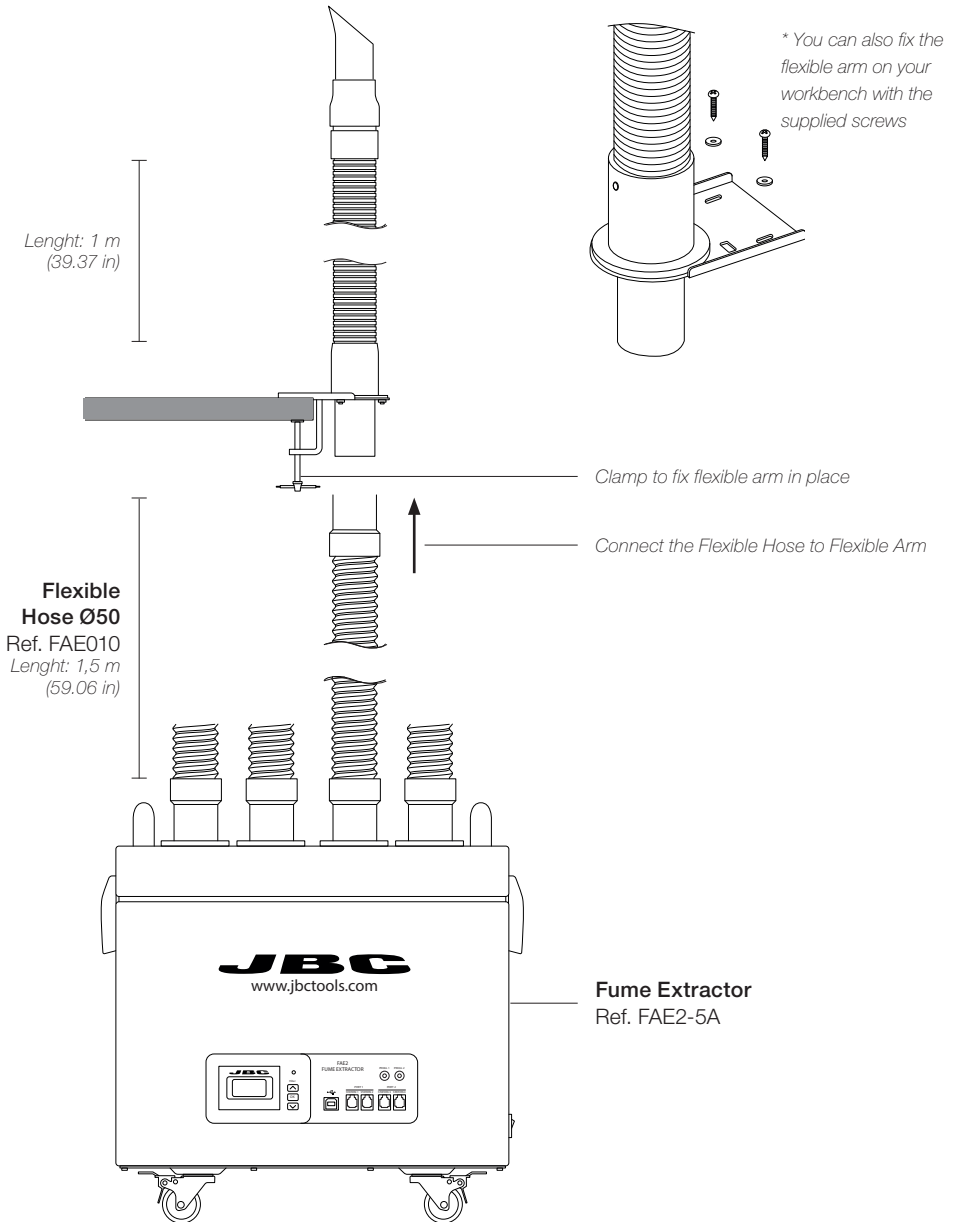

# Arm assembly

- When the flexible arm loses firmness, it must be re-compressed.
- For a greater compression, turn it slightly clockwise.
- Once the arm is compressed, adapt its position again.

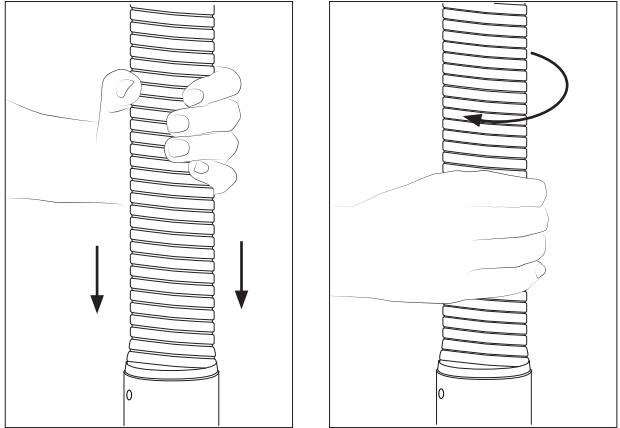

# Nozzles

You can replace the supplied nozzle and choose the one that best suits your needs.



**Round Nozzle for FAE Fume Extractor**  
Ref. FAE081



**Rectangular Nozzle for FAE Fume Extractor**  
Ref. FAE080

## Nozzle Replacement

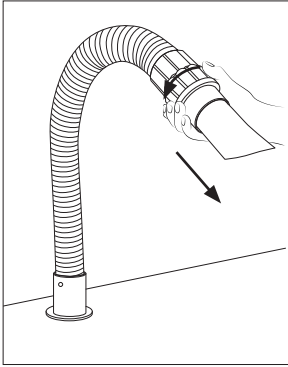

Turn the nozzle and pull out to remove it.

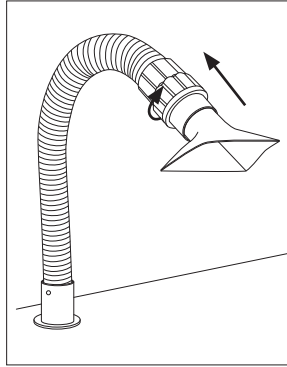

A bayonet fitting system allows a proper connection between the flexible arm and the nozzle.

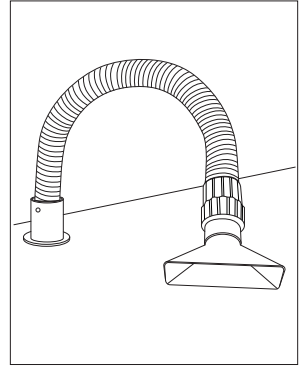

The nozzles are designed to work with the arm suspended and also supported on the work bench.

## Installation Guide Line

Follow these installation guidelines for proper use.

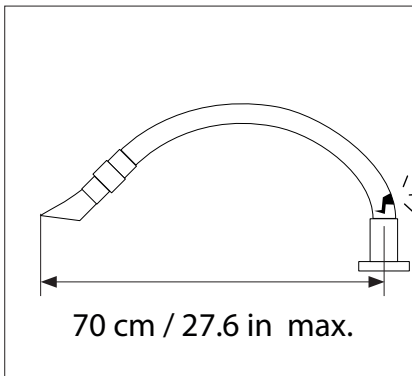

The recommended working area of the arm is 70 cm / 27.6 inches from the center of its base. Extending the arm more than this dimension could break it.

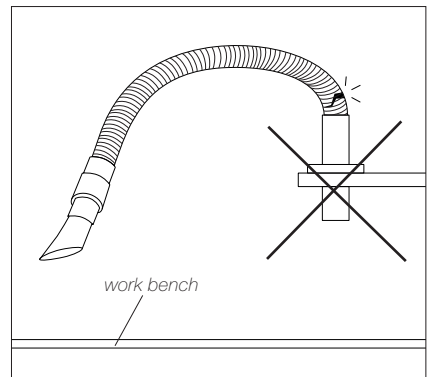

Do not install the flexible arm on shelves or higher levels than the work bench. Forced bending radii can cause arm breakage.

**!** In case of a breakage, the windings can be plugged back into each other. To do this, align the windings with one another and push them back together with strength.





# Specifications

## F AE070

### Flexible Arm + Clamp Ø 50 mm

Ref. FAE070

- Net Weight: 2,2 kg (4.9 lb)
- Length: 1 m (39.4 in)
- Inner Diameter: 50 mm (2 in)
  
- Total Package Dimensions / Weight: 1050 x 170 x 120 mm / 2.844 kg  
(L x W x H) 41.34 x 6.7 x 4.72 in / 6.2 lb

Complies with CE standards.  
ESD Safe.

# JBC

## Warranty

JBC's 2 year warranty covers this equipment against all manufacturing defects, including the replacement of defective parts and labour.

Warranty does not cover product wear or misuse.

In order for the warranty to be valid, equipment must be returned, postage paid, to the dealer where it was purchased.



This product should not be thrown in the garbage.

In accordance with the European directive 2012/19/EU, electronic equipment at the end of its life must be collected and returned to an authorized recycling facility.



[www.jbctools.com](http://www.jbctools.com)