

JBC

www.jbctools.com

Product
webpage



INSTRUCTION MANUAL



MSE

Electric Desoldering Module
for DDE & DME

This manual corresponds to the following reference:

MSE-B

Packing List

The following items are included:



**Electric Desoldering Module
for DDE & DME 1 unit**



Power Supply Adapter 1 unit
Ref. 0033723



Suction Filter Kit 1 unit
Ref. MS20



Front Filters 2 sets
Ref. MS10
(Each set contains 5 filters)



Cotton Filters 1 set
Ref. MS30
(Each set contains 10 filters)



Module Cable Connector 1 unit
Ref. 0024228



Manual 1 unit
Ref. 0032556

Features and Connections



MS10
Front Filter for MSE
(inside)

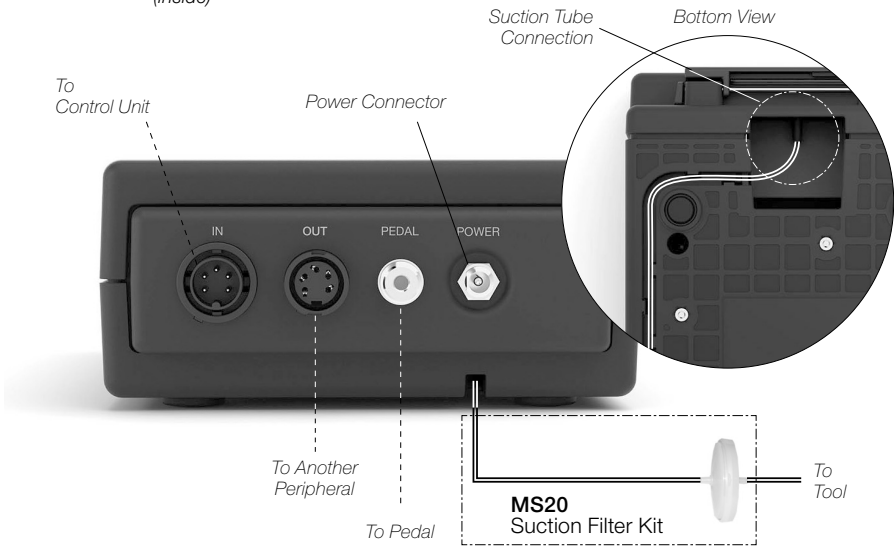

Compatibility

Select the equipment that best suits your soldering or desoldering needs.

Module	Stand	Tool	Tip Range	Control Unit		Peripheral
				DDE	DME	P405
MSE	DTS	DT530	D530	● <i>min. firmware version 8886903</i>	● <i>min. firmware version 8886909</i>	●
	DSS	DS360	C360	●	●	●
	DRS	DR560	C560	●	●	●

Initial Set up



After connecting the module, enter the **Peripherals** menu and select the port that you want to join with the module.

Peripherals

For DDE Control Unit

1. Select the module from the list of peripheral connections. Remember your first connection is denoted as "a", the second being "b", etc. (e.g. MSE_a, MSE_b,...)
2. Press Menu or Back to save changes.
Once set up, you can change the module settings by entering the **Peripherals** menu.

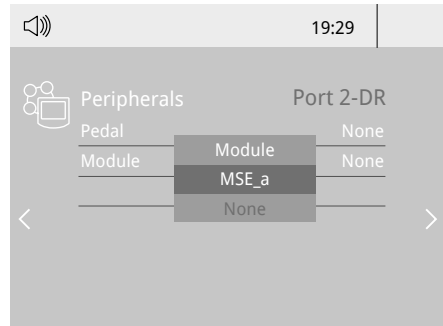

For DME Control Unit

When a new module is detected, a pop-up screen appears.

1. To configure your Electric Suction Module press Setup in the popup window.
2. Select the module from the list of peripheral connections. Remember your first connection is denoted as "a", the second being "b", etc. (e.g. MS_a, MS_b,...). Do the same with the pedal (e.g. PD_a,...)
3. Select the port of the tool you want to link to the peripheral.
4. Press Menu or Back to save changes.
Once set up, you can change the module settings by entering the **Peripherals** menu.

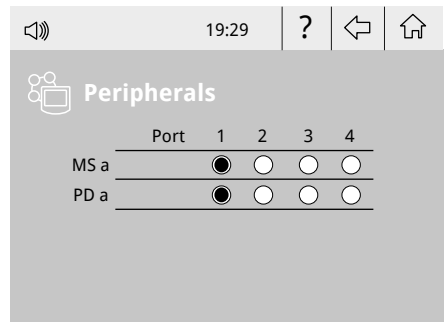
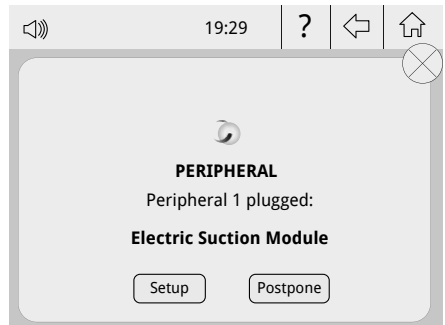

Working

Connect all components like shown on page 3.

Filters

Both the front filter and the suction filter kit must be used to avoid possible impairments.

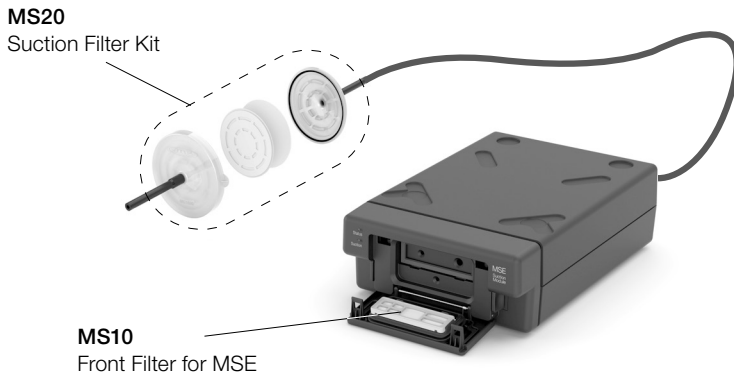

Clogging Detection

MSE has a built-in a clog detector. The desoldering module warns the user whenever there is a partial or total obstruction within the suction system (filter, module, hose or tool).

There are several reasons why the detector may report no air intake or a suboptimal airflow.

See the table on the next page to identify and solve any working issues.

Status and Suction Indicators

The suction and status indicators use color coding to report the operation status of the system, as shown in the table below.

Status Indicator	Suction Indicator	System Status	Recommendation / Solution
Light			
off	off	MSE not connected to the mains.	Connect MSE to the mains.
blue	off	MSE connected to the mains, but control unit not connected to MSE.	Connect MSE to the desoldering station.
green	off	Ready to operate (work).	To start the suction, press the tool button on the desoldering tool or operate the pedal if you are working with one.
green	green	Operating tool or pedal (working).	
green	red	Attempting to operate (suctioning), but not working. System clogged.	Mandatory: Stop to operate tool/pedal. In case of ... - <u>Leakage</u> : check if any tube is disconnected or damaged. - <u>Clogging</u> : clean the desoldering tip, check and replace saturated filters.
green	red blinking	Operation stopped. System clogged.	Mandatory in case of ... - <u>Leakage</u> : check if any tube is disconnected or damaged. - <u>Clogging</u> : clean the desoldering tip, check and replace saturated filters.

Replacing the Front Filter

In case of filter saturation follow these steps to replace the worn front filter:

Slide down (1) both side tabs on the front lid to open it (2).

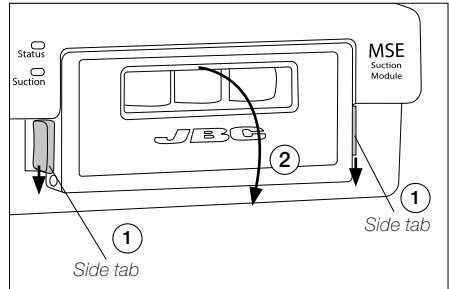

Remove the filter by pulling it upwards (3) out of the snap-fits of the seal.

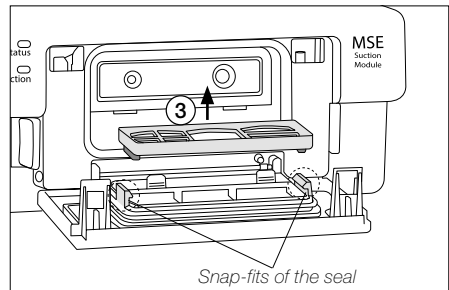

Position the filter with its black side facing down (4).

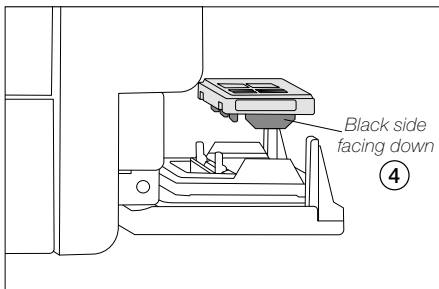

View from the left

Make sure that the cross-shaped strut (5), which is located on the top side (light-colored), is positioned on the left.

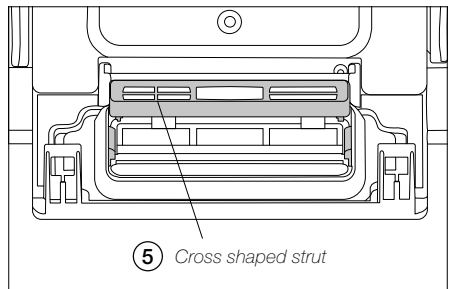

View from the front

Replacing the Front Filter - continuation

Center the filter between the snap-fits (6) of the black seal and push it in (7).

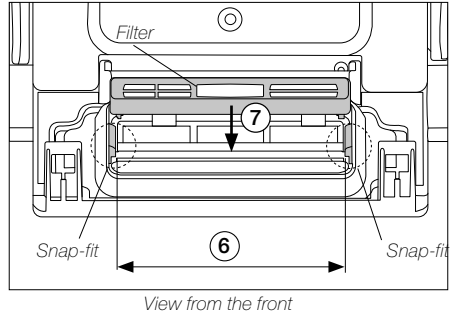

With the filter positioned flat between the snap-fits, push it back (8) until it stops against the transparent ribs.

Make sure that the snap-fits of the seal are slot into the lateral recesses (9) of the filter frame.

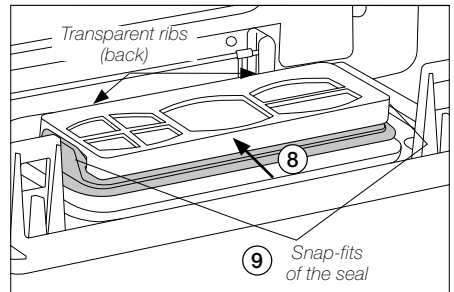

Close the front lid by pressing against both upper corners (10) until it clicks.

Note: If the lid does not close smoothly, check the positioning of the filter.

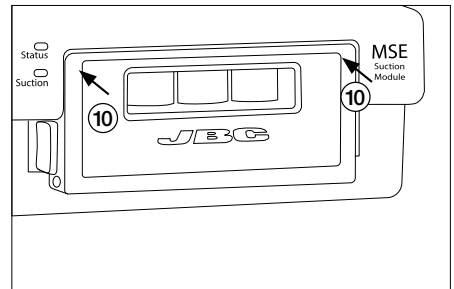

Replacing the Cotton Filters

There are two cotton filters inside the suction filter housing. In case of cotton filter saturation, they can be replaced with JBC's MS30 cotton filters.

To replace them, open the suction filter housing: Hold one side of the housing with one hand and with the fingers of the other hand press the tabs (1) on the other half of the housing to open it.

Take both worn filters out and replace them with two new ones. **Note:** do not insert more than 2 filters at the same time (2).

Before closing the housing make sure that the o-ring seal is correctly fitted in place (3).

Finally, press both parts of the housing together.

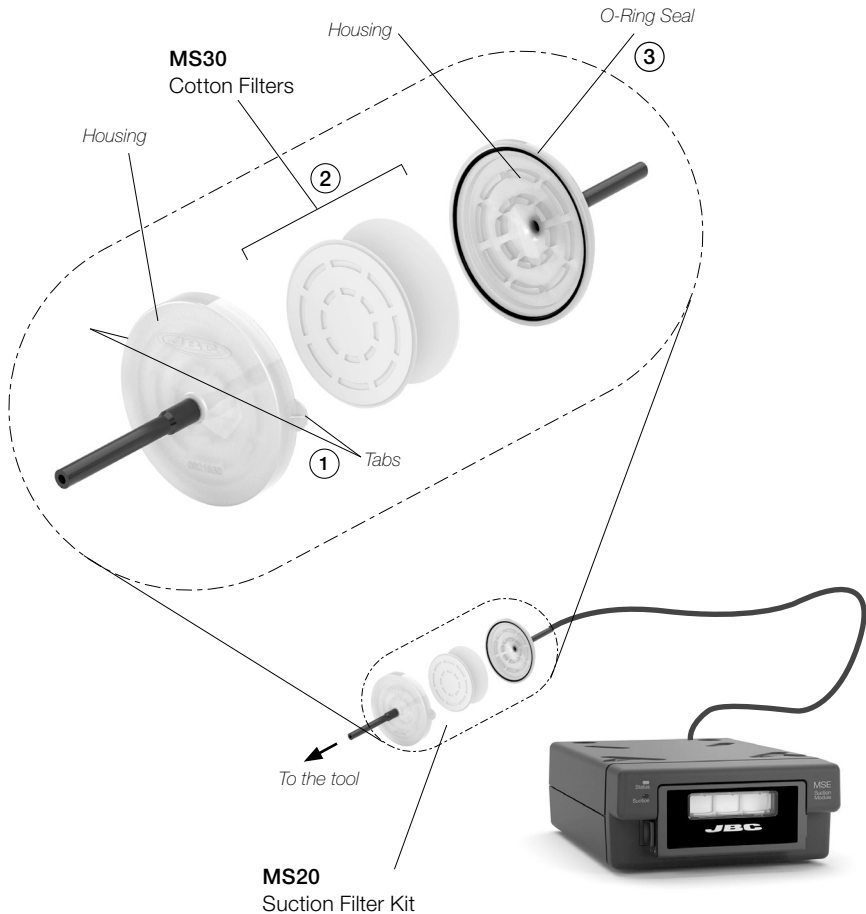

Maintenance

Before carrying out maintenance or storage, always unplug the equipment.

- Keep the casing clean by using a damp cloth. Especially use a soft cloth for the front side.
- Periodically check all cable and tube connections.
- Keep filters clean to ensure proper solder suction and replace them when necessary. Filter replacement see previous pages.
- Use original JBC spare parts only.
- Do not work with defective or damaged pieces.
- Repairs should only be performed by a JBC authorized technical service.
- Maintenance must not be carried out by children unless supervised.

Safety



It is imperative to follow safety guidelines to prevent electric shock, injury, fire or explosion.

- Do not use the units for any purpose other than soldering or rework. Incorrect use may cause a fire.
- The power cord must be plugged into approved bases. Be sure that it is properly grounded before use. When unplugging it, hold the plug, not the wire.
- Do not work on electrically live parts.
- The tool should be placed in the stand when not in use in order to activate the sleep mode. The soldering tip or nozzle, the metal part of the tool and the stand may still be hot even when the station is turned off. Handle with care, including when adjusting the stand position.
- Do not leave the appliance unattended when it is on.
- Do not cover the ventilation grills. Heat can cause inflammable products to ignite.
- Avoid flux coming into contact with skin or eyes to prevent irritation.
- Be careful with the fumes produced when soldering.
- Keep your workplace clean and tidy. Wear appropriate protection glasses and gloves when working to avoid personal harm.
- Utmost care must be taken with liquid tin waste which can cause burns.
- This appliance can be used by children over the age of eight and also people with reduced physical, sensory or mental capabilities or lack of experience provided that they have been given adequate supervision or instruction concerning the use of the appliance and understand the hazards involved. Children must not play with the appliance.
- Maintenance must not be carried out by children unless supervised.

Specifications

MSE

Electric Desoldering Module for DDE & DME

Ref.: **MSE-B**

- Power:	42 W
- Vacuum:	85 % / 640 mmHg / 25.4 inHg
- Flow Rate:	35 SLPM
- Ambient Operating Temperature:	10 - 40 °C / 50 - 104 °F
- Pedal Connection:	Yes
- ESD Safe:	Meets ANSI/ESD S20.20-2021
- Module Dimensions (L x W x H):	225 x 145 x 55 mm / 8.86 x 5.71 x 2.17 in
- Total Net Weight:	1.49 kg / 3.28 lb
- Total Package Dimensions / Weight: (L x W x H)	280 x 195 x 115 mm / 1.98 kg 11.02 x 7.68 x 4.53 in / 4.37 lb

Complies with CE standards.
ESD safe.

JBC

Warranty

JBC's 2 year warranty covers this equipment against all manufacturing defects, including the replacement of defective parts and labor.

Warranty does not cover product wear or misuse.

In order for the warranty to be valid, equipment must be returned, postage paid, to the dealer where it was purchased.



This product should not be thrown in the garbage.

In accordance with the European directive 2012/19/EU, electronic equipment at the end of its life must be collected and returned to an authorized recycling facility.

